

OCEAN SOLAS LIFERAFT

Owner's Manual

REV 2

This manual is the property of Ocean Safety Limited and its associated or subsidiary companies.

It must not be copied without prior written permission from Ocean Safety Limited or its associated or subsidiary companies.

All rights reserved.

**YOUR SAFETY
OUR WORLD**



1.0	INTRODUCTION	P3
2.0	TRANSPORT, STOWAGE, MAINTENANCE, STORAGE AND SERVICE ADVICE	P4
2.1	Safety guidelines for transportation to avoid accidental inflation of the liferaft	P4
2.2	Stowage guidelines	P5
2.3	Preventive maintenance On board	P7
2.4	Liferaft servicing	P8
3.0	OPERATING INSTRUCTIONS	P9
3.1	Launching the liferaft	P9
3.2	How to manually deploy the liferaft	P9
3.3	Deploying the liferaft from a ramp cradle	P10
3.4	Float free deployment	P11
3.5	Boarding the liferaft	P12
3.6	Righting the liferaft	P12
4.0	KNOW YOUR LIFERAFT	P13
4.1	Ocean SOLAS liferaft 6, 8, 10 & 12 person	P13
4.2	Ocean SOLAS liferaft 16 & 25 person	P14
4.3	Table 1: Equipment contained in manufacturers supplied equipment bag - SOLAS A	P15
4.4	Table 2: Equipment contained in manufacturers supplied equipment bag - SOLAS B	P16
5.0	IMMEDIATE ACTION	P17
5.1	Immediate action to be taken - On entering the liferaft	P17
5.2	Immediate action to be taken - Once inside the liferaft	P18
6.0	SURVIVAL GUIDELINES	P19
6.1	Once in - General maintenance of the liferaft	P19
6.2	Once in - Topping up pressure	P19
6.3	Small repairs to the buoyancy tube material	P20
6.4	Leader	P22
6.5	Survival instructions	P22
6.6	Dehydration prevention in tropical climates	P22
6.7	Exposure to the cold	P23
6.8	Water	P24
6.9	Food	P24
7.0	RESCUE	P25
7.1	Signal pyrotechnics	P25
7.2	Rescue signals, signal mirrors	P25
7.3	Rescue by helicopter	P26
7.4	Towing the liferaft	P26
8.0	SERVICE RECORD	P27

1.1 This manual has been compiled as a guide to the general transport, storage, stowage, maintenance, servicing and usage of your liferaft. Keep this manual in a safe place on board, it is recommended that it is accessible to all on board and content to be read and thoroughly understood before any action is taken with the liferaft.

1.2 Whilst the information provided is extensive, it may not be complete as regulations do vary from country to country. Therefore it is advisable to obtain further guidance from your local authority regarding the additional equipment to be carried or regulations to be met.

2.0.1 Before handling the liferaft, an understanding of the inflation system is recommended. Inside the container and attached to the liferaft as part of the inflation system, is a pressurised gas or air cylinder which needs to be handled with care.

2.0.2 The gas stored within the cylinder is a mixture of Carbon Dioxide (CO₂) and Nitrogen (N₂). Upon activation of the valve fitted to the cylinder, the gas is released into the chambers of the liferaft, providing its shape and buoyancy. The inflation is initiated by pulling sharply on the painter line. 2



WARNING: CAUTION SHOULD BE EXERCISED WHEN HANDLING AND TRANSPORTING THE LIFERAFT NOT TO INFLATE IT ACCIDENTALLY



WARNING: DO NOT TAMPER WITH THE GAS OR AIR CYLINDER



2.1 SAFETY GUIDELINES FOR TRANSPORTATION TO AVOID ACCIDENTAL INFLATION OF THE LIFERAFT



WARNING: AT ALL TIMES, ENSURE THE PAINTER LINE DOES NOT BECOME SNAGGED. IF THE PAINTER LINE IS ALLOWED TO BE PULLED TO THE END OF ITS FULL LENGTH, THE CYLINDER VALVE WILL BE ACTIVATED AND THE LIFERAFT CAUSED TO INFLATE



(For length of painter line, refer to the data label on the container)



WARNING: ENSURE THAT THE CONTAINER IS NOT SUBJECTED TO VIOLENT SHOCKS OR ALLOWED TO ROLL



WARNING: IF THE LIFERAFT IS TRANSPORTED BY CAR, IT MUST BE TRANSPORTED IN THE BOOT OF THE CAR. UNDER NO CIRCUMSTANCES SHOULD IT BE TRANSPORTED IN THE MAIN PASSENGER COMPARTMENT OF THE CAR



2.2 STOWAGE GUIDELINES

2.2.1 When selecting the position of the liferaft onboard the vessel, there are a number of points that require consideration.



WARNING: ALL CONTAINERS ARE SECURED WITH CRIMPED BANDS. THESE ARE AN INTEGRAL PART OF THE CONTAINER AND MUST NOT BE REMOVED



- Firstly the liferaft must be positioned so it can be easily accessed and deployed in an emergency situation. Nothing must be stored on top of the liferaft.
- Any strapping down of the liferaft to the desired location must be easy to remove, with no locking system requiring a key. Where possible any securing arrangement should incorporate a hydrostatic release unit (HRU). The liferaft should be positioned clear of any overhangs, rigging or any other object that may hinder the rafts deployment, especially if the liferaft is fitted with a HRU. (see Fig 1 for a common liferaft installation)
- The liferaft must NOT be positioned where it or its painter line are likely to become a trip hazard.
- At no time should the liferaft be used as a seat or be stood on.
- The liferaft must NOT be stowed in close proximity to any form of heat source.
- Stowages/cradles for the liferaft must be the correct size for the container and be secured to a solid part of the vessel.
- If in a flat/compact container, it may be mounted on its side end or preferably flat. Care must be taken not to block the drain holes in the bottom, side or end of the container. Containers stowed end on, MUST have the painter line exit hole uppermost. Containers stowed on their side, MUST be orientated with the cylinder close to the deck (i.e, painter exit hole at deck level).
- If connected to a HRU (best practice) then only withdraw sufficient painter line to reach and tie off to the link on the HRU. (see Fig 2 for simple HRU configuration).
- For further advice or clarification, contact Ocean Safety.

2.2.2 In a common installation, the liferafts, packed in their containers, are arranged in cradles at specific points of a vessel. The cradle should be permanently affixed to the deck.

2.2.3 Each liferaft is secured to the cradle by strapping. One end of the strapping should be secured to the cradle, the other end should be connected to a HRU via a Quick Release or Slip Hook. The HRU should in-turn be connected to the cradle via a weak link.

2.2.4 The liferaft painter line should be connected to the weak link of the HRU.

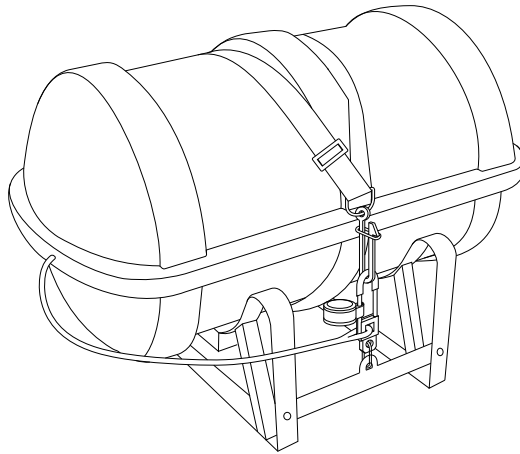

Fig 1 - Common Installation

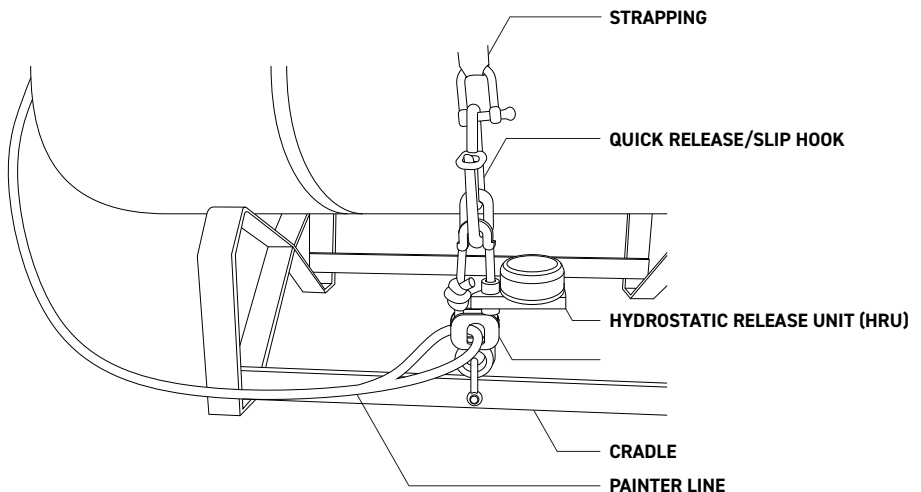

Fig 2 - HRU Configuration

2.3 PREVENTIVE MAINTENANCE | ON BOARD

2.3.1 Containers must be kept clean

- Cleaning must ONLY be carried out using a solution of soap and water.
- Rinse off soap and water solution using clean, fresh water.
- Rub down with a clean, dry cloth.

2.3.2 Monthly maintenance

- Ensure that the container is strapped firmly into its cradle.
- Inspect the container for damage, cracks, chafing or weakness.
- Inspect the securing straps for cuts, abrasion or other damage to the webbing or stitching.
- Ensure the painter line is not showing signs of abrasion and that it is still attached to the strong point on the deck, preferably through a HRU.
- Ensure that the HRU is within its operational life. For more details, refer to the HRU instruction manual.

2.3.3 Storing the liferaft | Off the vessel

2.3.3.1 If the liferaft is to be stored for any length of time:

- Choose a site that is clean, dry and away from direct sunlight and where the temperature is between 10°C and 30°C.
- Ensure that rodents can not access the liferaft. Rodents can and will eat the fabrics used to manufacture the liferaft.
- Store the liferaft away from contaminants such as oils, fuel and other chemicals.

2.3.3.2 If the liferaft is to be stored for more than 3 months, it is advisable to have it serviced at an Ocean Safety approved service centre prior to reinstalling back on board.

2.4 LIFERAFT SERVICING

- This Ocean SOLAS liferaft MUST be serviced at an Ocean Safety approved service station.
- The service data is shown on the labelling of the liferaft container.
- The approved service station will complete the 'Liferaft Service Record Card' shown in this manual.
- The approved liferaft service station will issue a certificate of re-inspection which should be kept safely onboard.
- No product liability can be accepted by Ocean Safety for liferafts serviced at non-approved service stations.

2.4.1 For more details on Ocean Safety global service stations please visit;

www.oceansafety.com/servicing

3.1 LAUNCHING THE LIFERAFT

3.1.1 In preparation for an emergency, ensure that ALL persons onboard the vessel are aware of the location and operation of the liferaft. Make a MAYDAY call. Ensure that everybody on board is wearing a lifejacket and that it is fitted correctly. Remember to locate a 'Grab Bag' and fill with the necessary survival equipment, take sea sickness tablets if time permits.

3.2 HOW TO MANUALLY DEPLOY THE LIFERAFT

1. Release any strapping securing the liferaft to the stowage point.



WARNING: DO NOT OPEN THE CONTAINER MANUALLY. THE CONTAINER IS DESIGNED TO OPEN AUTOMATICALLY WHEN THE LIFERAFT IS IN THE WATER AND THE PAINTER LINE IS PULLED.



- OR -

IF NOT ALREADY FITTED TO A HRU, PULL OUT SUFFICIENT PAINTER LINE AND SECURE IT TO A STRONG POINT ON THE DECK.

(Note: It is not necessary to pull out all the painter line as it will deploy as the container descends to the water)

2. Throw the container overboard.
3. To inflate the liferaft, pull firmly on the painter line to its full extension and the liferaft will inflate. During the inflation of the liferaft, it is normal for there to be a hissing sound as the gas enters the chambers and the excess is exhausted through the relief valves. It is also normal to see the excess gas venting through the relief valves.
4. To avoid entering the water and aid boarding, secure the liferaft close to the vessel.



3.3 DEPLOYING THE LIFERAFT FROM A RAMP CRADLE

1. If the liferaft is mounted to a ramp cradle, release the Quick Release/Slip Hook (see Fig 3).
2. With the strapping removed, the container(s) will roll down the ramp under its own momentum.
3. As the container(s) fall, the painter line will be pulled free.
4. To inflate the liferaft, pull firmly on the painter line to its full extension and the liferaft will inflate. During the inflation of the liferaft, it is normal for there to be a hissing sound as the gas enters the chambers and the excess is exhausted through the relief valves. It is also normal to see the excess gas venting through the relief valves.
5. To avoid entering the water and aid boarding, secure the liferaft close to the vessel with bousing lines (if fitted).

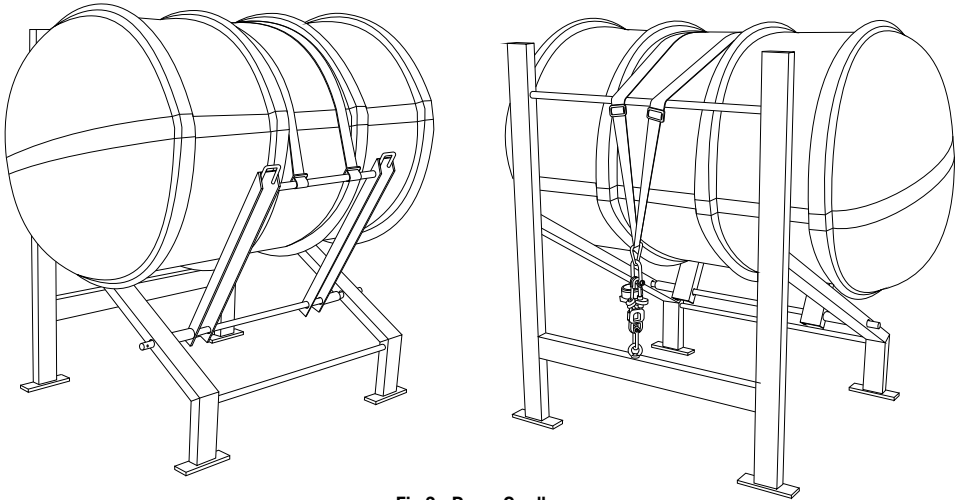

Fig 3 - Ramp Cradle

3.4 FLOAT FREE DEPLOYMENT

3.4.1 In some circumstances, the ship may sink before the liferaft can be manually deployed. Unless fitted with a HRU, the liferaft will sink with the ship and will not automatically deploy.

3.4.2 The HRU will deploy at a depth between 1.5m and 4m via the action of hydrostatic pressure. This will release the liferaft from its mounting point/strapping and the liferaft will float free from the ship. The painter line remains attached to the ship via the HRU weak link (see Fig 4).

3.4.3 Once the painter line has reached its maximum length, the inherent buoyancy of the liferaft will activate the gas inflation system and the liferaft will inflate. The buoyancy of the liferaft will break the HRU weak link allowing the liferaft to reach the surface ready for boarding (see Fig 4).

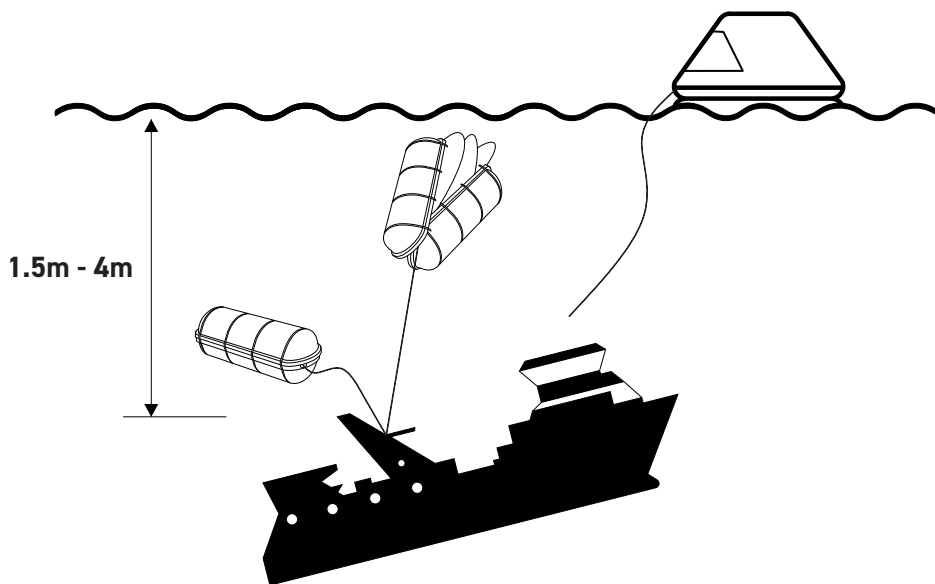

Fig 4 - Float Free Deployment of the Liferaft

3.5 BOARDING THE LIFERAFT

3.5.1 Once the liferaft is alongside the ship and secured, survivors can embark in a number of ways:

- Descend via a rope ladder
- Jump from the deck (if not too high)
- Via the boarding ramp or ladder (primarily for people in the water)

3.6 RIGHTING THE LIFERAFT

3.6.1 In the event the liferaft inflates in a capsized position, follow the steps below to right the liferaft:

1. Swim to the side of the liferaft where the cylinder is mounted.
2. Manoeuvre the liferaft so you are facing the direction of the wind.
3. Place your feet on the cylinder, take the righting line, extend your legs and lean back.
4. Using a hand-over-hand action, climb up the righting line and continue until the liferaft is righted.
5. Whilst retaining a firm grip on the righting strap, pull the liferaft over to a boardable position (Fig 5).

3.6.2 Keep a firm grip on the righting strap throughout the procedure. Failure to do so could result in the liferaft righting on top of you (Fig 6), or given high winds, the liferaft may travel rapidly down wind after righting.

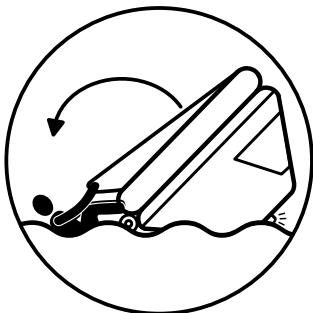

Fig 5 - Pull the righting strap and flip the raft

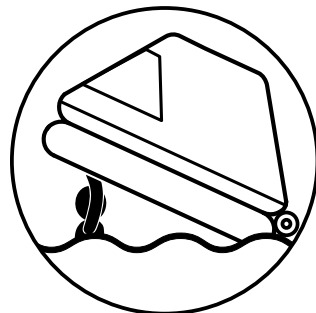
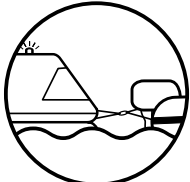

Fig 6 - Keep a firm grip on the righting strap

4.1 OCEAN SOLAS LIFERAFT 6, 8, 10 & 12 PERSON



Number of crew



Towing patch

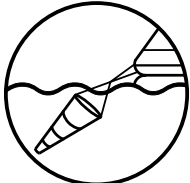

Sea anchor



Rain collector



Safety knife



Rescue quilt

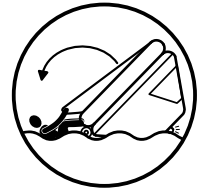
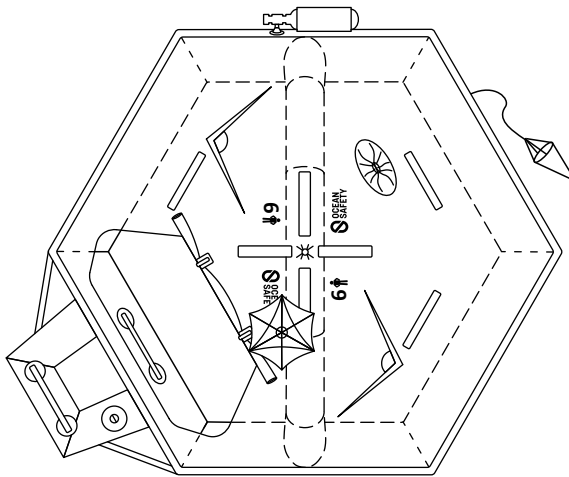
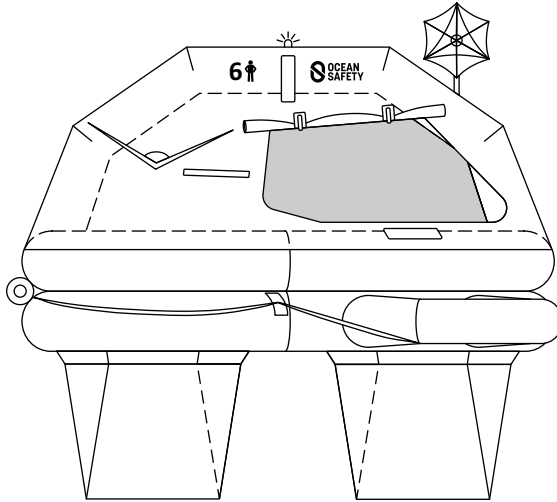

Righting line

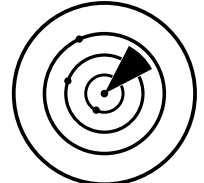

Radar Reflector

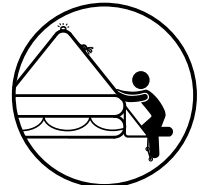

Boarding ramp

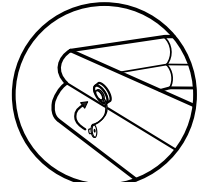

Relief valve plug

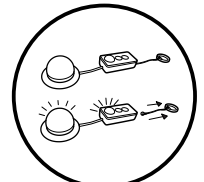

Light operation

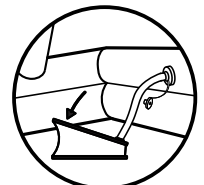

Top up valve

4.2 OCEAN SOLAS LIFERAFT 16 & 25 PERSON



Number of crew

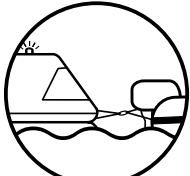

Towing patch

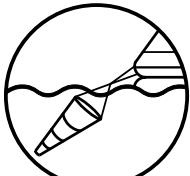

Sea anchor



Rain collector



Safety knife



Rescue quilt

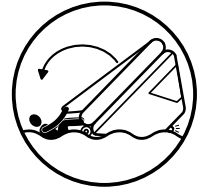
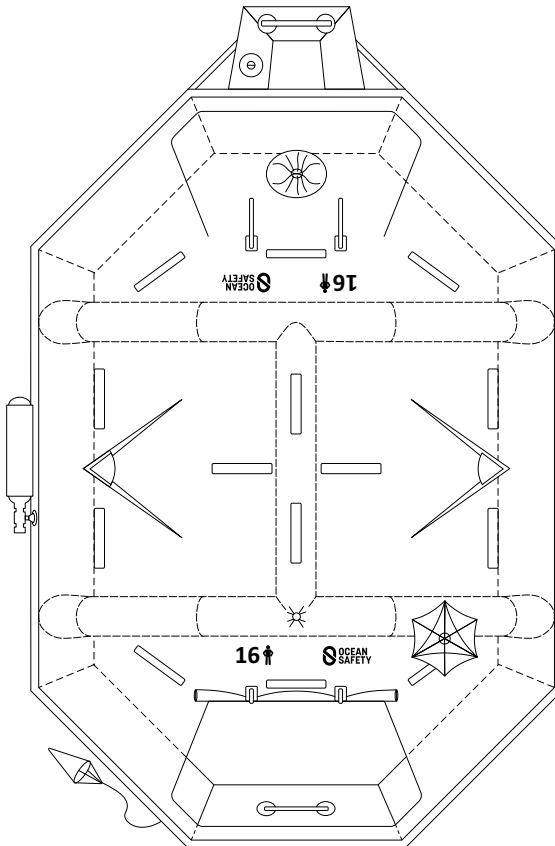
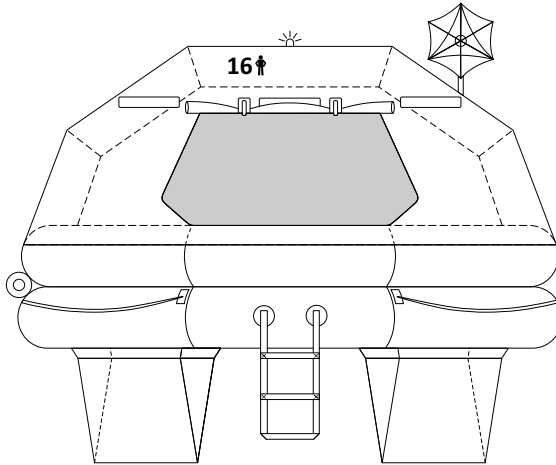

Righting line

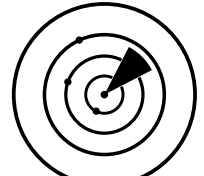

Radar Reflector

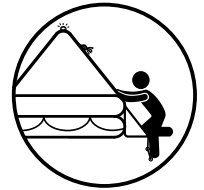

Boarding ramp

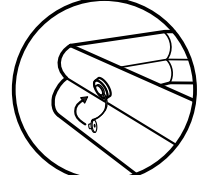

Relief valve plug

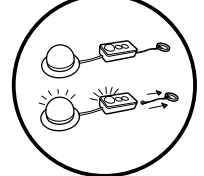

Light operation

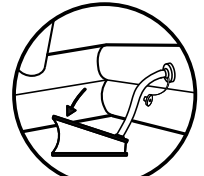

Top up valve

4.3 TABLE 1 : EQUIPMENT CONTAINED IN MANUFACTURES SUPPLIED EQUIPMENT BAG - SOLAS A

Equipment	6-12 MAN	16-25 MAN
Spare Sea Anchor/Drogue	1	1
Bailer	1	2
Safety Knife	1	2
Sponge	2	2
Set of Paddles	1	1
Tin Opener	1	1
Scissors	1	1
Cat C Medical Kit	1	1
Whistle	1	1
Red Hand Flare	6	6
Red Parachute Pocket	4	4
Orange Buoyant Smoke	2	2
Torch (c/w spare bulb and spare batteries)	1	1
Radar Reflector	1	1
Signal Mirror	1	1
No2 SOLAS Card	1	1
Fishing Kit	1	1
Food Rations (10,000Kj)	1/pp	1/pp
Water (1.5L)	1/pp	1/pp
Drinking Vessel	1	1
Seasickness Pills	6/pp	6/pp
Seasickness Bags	1/pp	1/pp
Thermal Protective Aid (TPA)	2	2
Repair Kit	1	1
Bellows/Air Puimp	1	1

4.4 TABLE 2 : EQUIPMENT CONTAINED IN MANUFACTURES SUPPLIED EQUIPMENT BAG - SOLAS B

Equipment	6-12 MAN	16-25 MAN
Spare Sea Anchor/Drogue	1	1
Bailer	1	2
Safety Knife	1	2
Sponge	2	2
Set of Paddles	1	1
Cat C Medical Kit	1	1
Whistle	1	1
Red Hand Flare	3	3
Red Parachute Pocket	2	2
Orange Buoyant Smoke	1	1
Torch (c/w spare bulb and spare batteries)	1	1
Radar Reflector	1	1
Signal Mirror	1	1
No2 SOLAS Card	1	1
Fishing Kit	1	1
Seasickness Pills	6/pp	6/pp
Seasickness Bags	1/pp	1/pp
Thermal Protective Aid (TPA)	2	2
Repair Kit	1	1
Bellows/Air Puimp	1	1

5.1 IMMEDIATE ACTION TO BE TAKEN - ON ENTERING THE LIFERAFT

1. Locate the paddles, emergency pack and the drogue inside the liferaft.
2. Cut the painter line with the liferafts knife (located on the right hand side of the canopy opening) and paddle clear of the evacuated vessel (Fig 7).
3. Once a safe distance away from the vessel, deploy the drogue (Fig 8).
4. Ensure that the liferaft is in good condition, bail water out of the liferaft and check that the side walls and arch are firm to the touch and there are no obvious leaks.
5. Look for and pick up other survivors. Throw quoit to survivors to aid recovery to the liferaft (Fig9).
6. Close entrances in the canopy.
7. Read this manual located inside the liferaft. During hours of darkness, use the internal liferaft light as a source of illumination.



Fig 7 - Cut the painter line

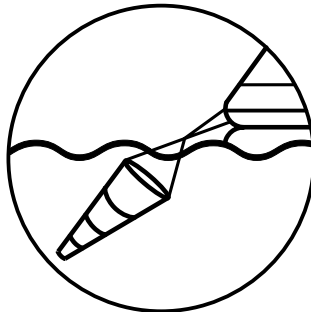

Fig 8 - Deploy the drogue



Fig 9 - Throw quoit to aid survivors

5.2 IMMEDIATE ACTION TO BE TAKEN - ONCE INSIDE THE LIFERAFT

1. Inspect the inflated tubes of the liferaft including the arch. If necessary, top up the pressure using the pump provided.
2. Distribute the weight within the liferaft evenly. Everyone should sit with their back to the inflated tubes with feet towards the centre.
3. As soon as possible, issue one dose of seasickness tablets to all occupants of the liferaft and make sure they are taken immediately.
4. To recover survivors from the water, use the rescue quoit and line to haul in conscious persons (Fig 9).
5. Elect a leader to take control of all procedures inside the liferaft while awaiting rescue.
6. Check that the drogue is correctly deployed (Fig 8) by pulling on the line. If the drogue has opened correctly you will feel resistance.
7. If there are other liferafts in the area, stay close together. Tether liferafts together if possible.
8. Take the radar reflector (if included) from the equipment bag and fit as instructed by the manufacturer.
9. If beaching the liferaft, use the paddles provided to steer clear of any sharp objects or rocks. If possible, pick a beach with a gentle gradient. Pull the liferaft well clear of the rising water line, anchor and leave.
10. Ensure that the external light is turned off in the hours of daylight to preserve battery power.

6.1 ONCE IN - GENERAL MAINTENANCE OF THE LIFERAFT

6.1.1 At all times, ensure that the floor of the liferaft is as dry as possible. Use the bailer and sponges provided in the equipment bag to bail excess water out of the liferaft. Puncturing the liferaft can have serious effects on its lifespan. Ensure that no sharp objects are allowed to be brought into the liferaft that are not essential. Those that are required, **MUST** be stowed safely.

6.2 ONCE IN - TOPPING UP PRESSURE

6.2.1 When entering the liferaft, the inflated tubes and arch should be firm to touch. Over time, the gas will permeate through the material of the liferaft. The result of this will be the loss of pressure and the feeling of the tubes and arch becoming softer. Maintain the pressure in the tubes of the liferaft by using the pump provided in the equipment bag.

6.2.2 Locate the pump, fit to the top up valves located near the entrance to the liferaft. Use the pump to top up the chambers (Fig10). Ensure the relief valves are not blocked (Fig 11) when this is done. Once this has been completed, remove the pump and replace the sealing cap securely (Fig 12).

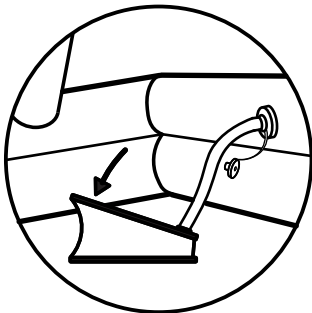

Fig 10 - Use the pump to top up the chambers

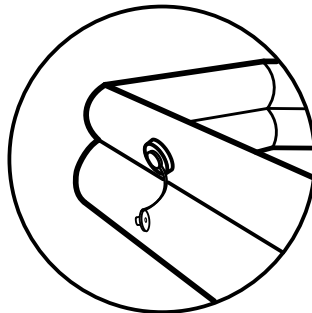

Fig 11 - Ensure pressure relief valves are not blocked

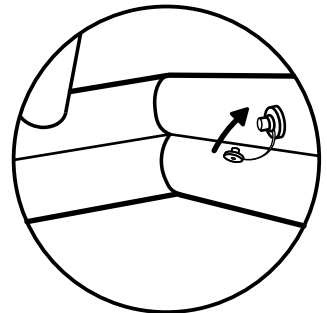

Fig 12 - Secure the sealing caps

6.3 SMALL REPAIRS TO THE BUOYANCY TUBE MATERIAL

6.3.1 Contained within the emergency packs are means to repair small tears or holes in the buoyancy tubes. The system supplied is a clamping unit that may be fitted whilst the fabric is wet. The clamps are supplied with the instructions, but familiarisation with the clamps operation is strongly advised before the liferaft is installed onboard a vessel. The shell puncture seal is an emergency seal for punctures at sea and ashore.

1. The method of sealing allows for it to be used underwater. It is simple to use and is a quick and easy way to make sure you stay afloat. Locate the hole or leak (Fig 13).
2. The hole needs to be large enough to accommodate the second half of the seal. The seal requires a minimum of 50mm clearance. If the hole is not larger enough, expand the hole until it is large enough for the seal, about 50mm (Fig 14). The maximum hole that can be sealed is 90mm.

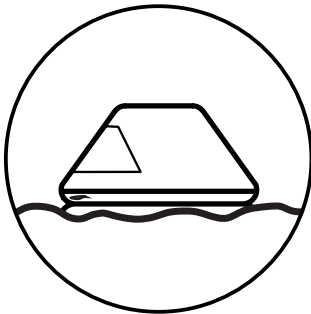

Fig 13 - Locate the hole or leak

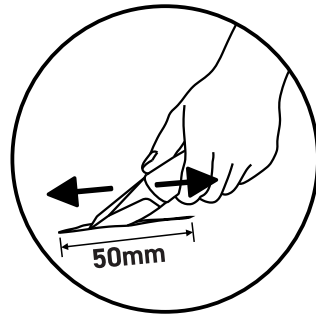

Fig 14 - Extend the hole to around 50mm

3. Unscrew the wing nut on the seal and pull the halves apart. Place the bottom half into the tear/split (Fig 15). Take care to make sure the line and the other half are both outside the tear/split.
4. Twist the lower half as you place it into the split (Fig16).

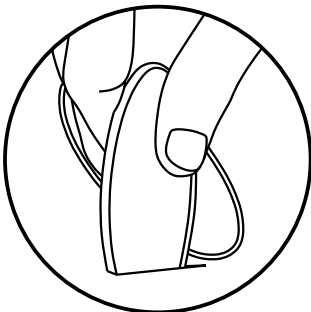

Fig 15 - Place bottom half into tear/split

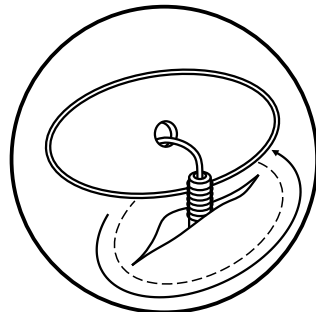

Fig 16 - Twist lower half to align with tear/split

5. Tighten the string on the seal (Fig 17) and allow the top half to fall into place over the second half. Make sure the thread comes through the hole in the top half.
6. Slide the wing nut over the thread, engage and tighten the wing nut (Fig 18). Only hand tighten the wing nut. This pressure is enough to maintain the seal.
7. Reinflate the tube using the pump included (Fig 19). A permanent repair should be installed as soon as possible.

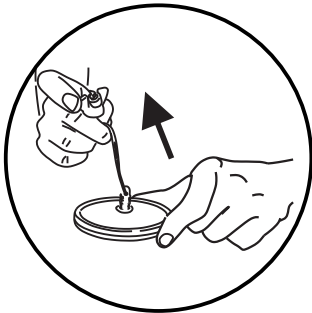

Fig 17 - Tighten string and position top half

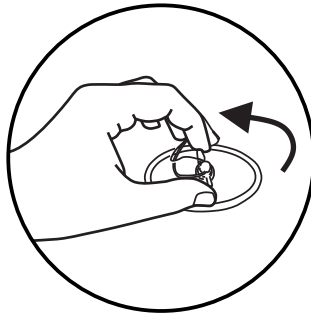

Fig 18 - Engage wing nut, hand tighten only

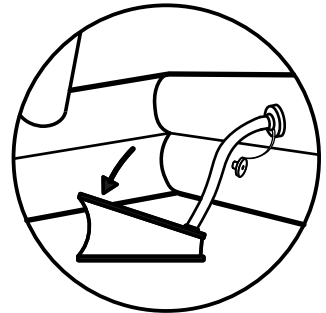

Fig 19 - Reinflate the tube

6.3.2 This seal can be taken off and reused in future situations.

6.4 LEADER

6.4.1 On board a liferaft, one person must take charge. This person's responsibilities include the maintenance of the liferaft and morale of the occupants which is possibly the most difficult task they undertake. This can be done by organising tasks and other activities.

6.4.2 Responsibilities of the leader

- Keep the liferaft clean and dry. Use bailer/sponge supplied to bail out excess water as and when required.
- Check that the equipment is securely stowed inside the liferaft.
- Ensure that there are no unnecessary sharp objects onboard the liferaft.
- Adjust the canopy to ensure good ventilation inside the liferaft.
- In rough seas or bad weather, move all weight inside the liferaft towards the direction of the wind.
- If necessary deploy the second drogue (if fitted) in rough weather.
- Delegate tasks such as watches or keeping a diary to pass the time.
- Conserve the battery life of the internal and external lights by ensuring they are only activated at night.

6.5 SURVIVAL INSTRUCTIONS

6.5.1 Onboard the liferaft, the conditions will determine the level of danger to the survivors. In hot conditions the main danger is likely to be the heat and dehydration. In cold conditions, exposure to the cold may be the biggest danger. An ongoing assessment of conditions must be made and proactive and reactive responses planned to ensure the well being of the survivors.

6.6 DEHYDRATION PREVENTION IN TROPICAL CLIMATES

6.6.1 To prevent the onset of dehydration in tropical conditions, it is possible to conserve the bodies supplies of water, rather than add water. Every effort must be made to conserve energy and stay out of the sun to prevent any type of sunburn or exposure.

6.7 EXPOSURE TO THE COLD

6.7.1 Exposure to the cold can be life threatening because of the reduction in the bodies temperature. This can be in one localised area such as hands or feet, giving possible frostbite or throughout the body lowering the core temperature causing hypothermia.

6.7.2 Thermal Protective Aids (TPA) are included in the emergency pack. If a casualty is suffering from the effects of hypothermia, they should be placed inside a TPA.

6.7.3 Where possible, another person should also be placed inside the TPA with them. In the case of frostbite, the affected area requires warming, which can be done by placing the area in a warm place such as under the arm pits. If suffering from frostbite the area must not be rubbed to warm it up, this could cause further injury.

6.7.4 To keep warm inside the liferaft and prevent the possible onset of these conditions:

- Conserve body heat by huddling together.
- Ensure the liferaft is kept as dry as possible.
- Keep clothes as dry as possible. If someone has entered the water then their clothes should be wrung out and put back on. Damp clothes offer better protection than none. Where possible wet clothes should be replaced with dry ones.
- Maintain the circulation around the body through massage four to five times a day unless you are suffering from the effects of frostbite or immersion foot.
- Survivors that are suffering from a low core temperature should be given a hot drink and be placed inside a TPA.
- Food and exercise increase the bodies ability to protect itself against the cold. Where possible, these activities should be encouraged.

6.8 WATER

6.8.1 The liferaft is fitted with a rainwater collector in the canopy. This should be used whenever possible to supplement the water rations. Water should be sparingly consumed but often. Water can also be collected from condensation on the inside of the canopy, and dew on the outside of the canopy.

6.8.2 When using the rainwater collector, first test the water for signs of salt. If the water tastes salty, then it should not be consumed. If the sample is clear of salt, use the plastic bag to collect further water or any other suitable receptacle. When it is rough, it may not be possible to collect drinkable water so it is better to think ahead.

6.8.3 At no time should you:

- Drink alcohol.
- Drink sea water, even if diluted.
- Drink urine, even if diluted.

6.9 FOOD

- Do not consume any food for the first 24 hours.
- Avoid the consumption of sweet or salty foods.
- Food rations should be distributed at a rate of one per person every 6-8 hours.
- Fish and/or sea birds may be caught and eaten.
- Plankton found on the bottom of the liferaft is also edible.

7.1 SIGNAL PYROTECHNICS

7.1.1 To be rescued, first you must be spotted. To do this, use any means necessary. In the equipment bag supplied, there are a number of pyrotechnic signals. These can be used to attract attention, but must be used sparingly and at the right time. The signals supplied in the equipment bags are as follows:

- Parachute signal
- Hand flares
- Smoke signals

7.1.2 With all the signals, correct use is vital for operational efficiency and safety of the persons onboard the liferaft. The parachute signals and hand flares can be used to attract attention at night time. These signals have limits to an effective range, reliant on correct use, weather and visibility.

7.1.3 As a maximum figure in perfect calm clear conditions, the following applies:

- Rocket parachute flares - 25-35 miles
- Hand flares - 5-10 miles

7.1.4 The smoke signals must only be used during hours of daylight and the effective range of the signal is dependent on the weather conditions at the time. All signals must be operated as per the manufacturers instructions. When operating the pyrotechnic signals, great care must be taken not to cause injury to any persons in the liferaft or damage to the fabric of the liferaft. Signals must be operated outside of the liferaft and downwind. At no time should a parachute signal be used in close proximity to a helicopter.

7.1.5 Only use pyrotechnics if you can see a means of rescue by line of sight. Always take into account the maximum range of the signals and weather conditions.

7.2 RESCUE SIGNALS, SIGNAL MIRRORS

7.2.1 Unlike pyrotechnics, the signal mirror can be used continually. In addition to this, the mirror can be used at night or day. If there is a means of rescue in sight, do not stop using the signal mirror. Only stop when the rescuer has clearly signalled that they have seen you.

7.3 RESCUE BY HELICOPTER

7.3.1 Under no circumstances should you use a parachute signal in close proximity to a helicopter.

7.3.2 Any rescue involving a helicopter must be performed following the instructions from the crew of the helicopter. In addition to this, the following must be observed:

- Remove any aerial or radar reflector that has been erected.
- Aid the pilot by indicating the direction of the wind. Do this by the use of a flag, strip of material or smoke signal.
- All persons onboard the liferaft should assist the recovery of persons from the liferaft by lying still while others are maneuvering into position. Ensure that the liferaft is balanced at all times.
- Ensure that no part of the helicopter's lifting equipment can become entangled in the liferaft.
- At no time should any part of the helicopter's lifting equipment be attached to the liferaft. If a stretcher needs to be used for a casualty then the stretcher must be detached while the injured party is secured.

7.4 TOWING THE LIFERAFT

7.4.1 Where possible this should be avoided. The liferaft has been tested up to a speed of 3 knots and this speed should never be exceeded. If towing is required then use the towing points on the liferaft (Fig 20).

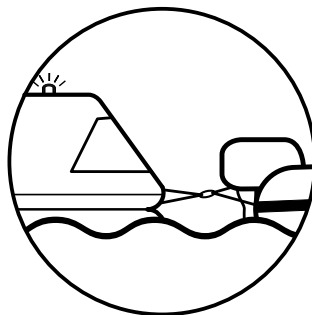

Fig 20 - Towing the raft

8.0 SERVICE RECORD



Date of Service	Service Station Address	Modifications	Repairs and/or Replacements	Comments	Signature & Stamp

OCEAN SAFETY
Saxon Wharf
Lower York Street
Southampton
Hampshire
SO14 5QF

Tel: +44 (0)2380 720800
Email: info@oceansafety.com
Web: www.oceansafety.com

YOUR SAFETY
OUR WORLD

